



Our Mission

Seeking safety, comfort, eco-friendliness and convenience for public transportation and life.

Our Vision

Becoming a globally influential provider of passenger transport system solutions (Products & Service).

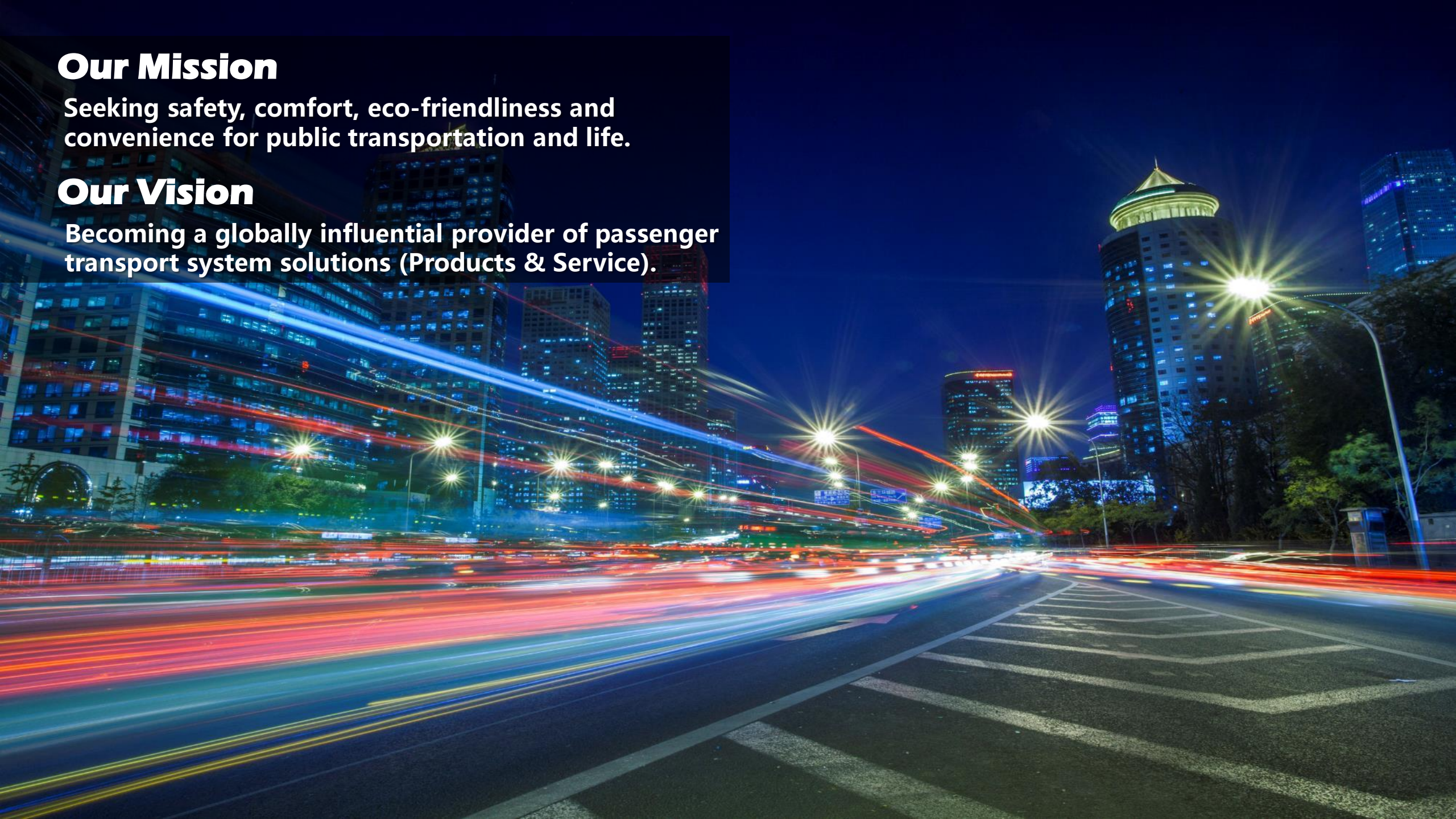

OVERVIEW

PRODUCT

MANUFACTURING AND R&D

SERVICE

SOCIAL RESPONSIBILITY

OPERATION ALL OVER THE WORLD

CONTENTS

A scenic landscape at sunset. The sun is low on the horizon, casting a warm, golden glow over the scene. The sky is a mix of deep blue and orange, with wispy white clouds. In the foreground, a paved road with a white dashed line curves towards the right. To the left of the road is a metal guardrail. In the background, a hillside rises, covered in green and brown vegetation. Several small figures of people can be seen on the crest of the hill. The overall mood is peaceful and contemplative.

Overview

- Established in 1988
- Engaged in R&D, production and sales of coaches, buses and minivans
- Specializing in the products of 4.8m-18m buses and coaches
- Cumulative sold more than 400,000 vehicles
- Exported to more than 130 countries and regions worldwide
- Employees up to 5300, over 800 Engineers, nearly 300 design patent and technological innovation
- Ranking top 10 of automobile brands in China with the brand value RMB 30.645 billions



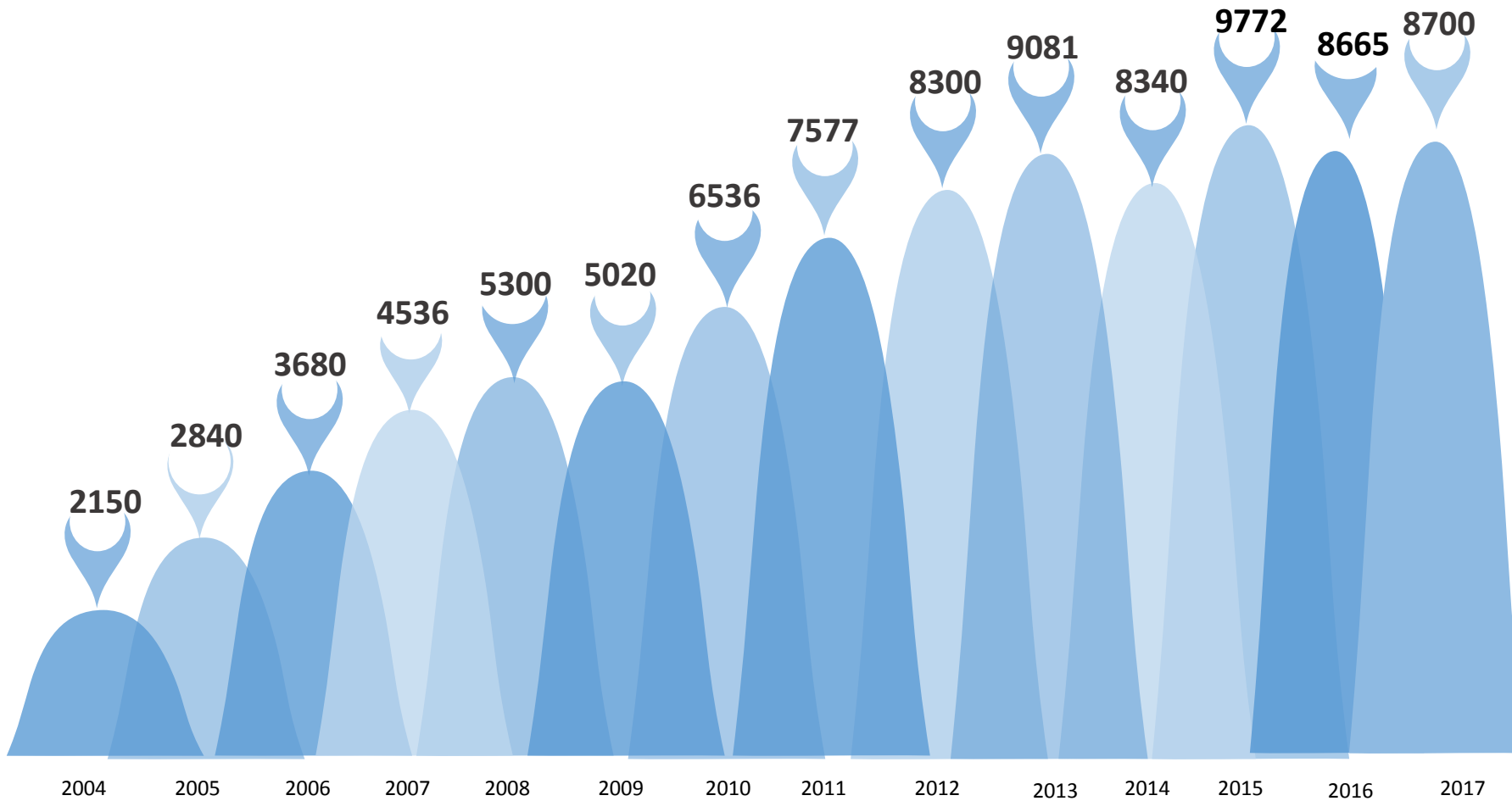

In 2017

- Exported **8700** units
- Sales volume ranked **No.1** in the industry
- Sales amount ranked **No.2** in the industry

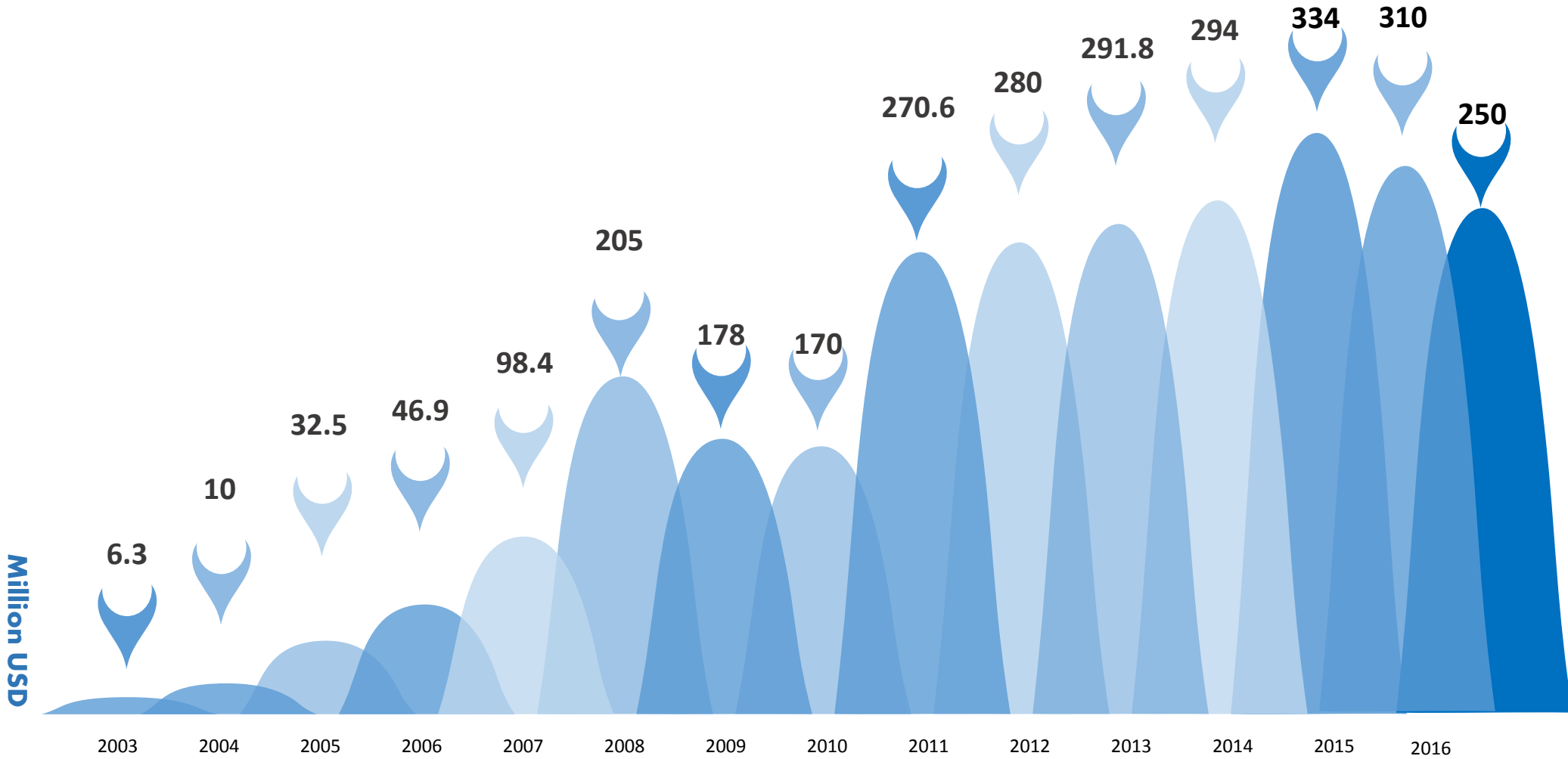

- Began to expand overseas market in 2000
- Cumulative export bus volume reaches **100,000** units

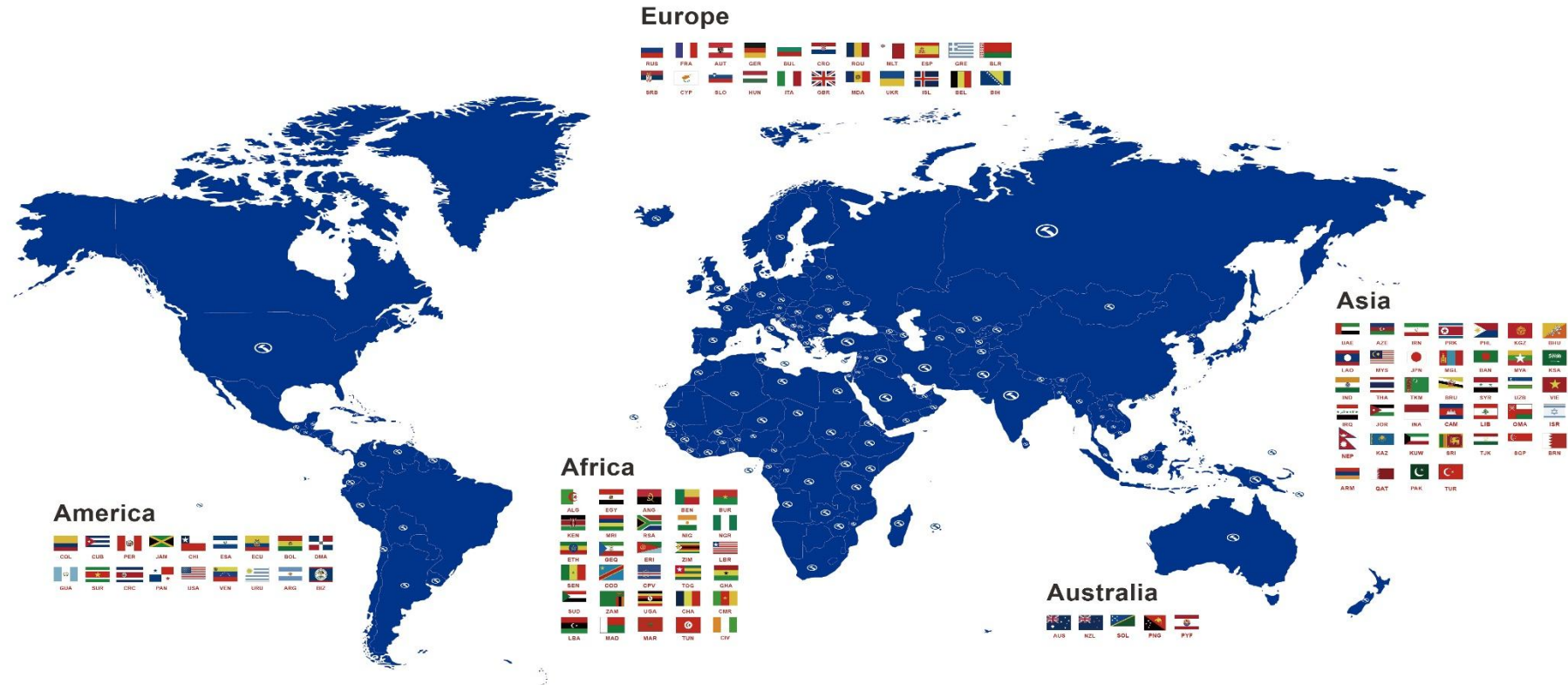

More than **60** distributors

Exported to **136** countries & regions



Busbuilder of the Year 2010



TS16949:2009



Exempted from Export Inspection



VCA Certification



Russian GOST R Certification



Australian ADR Certification



GCC Certification



National Technology Center

- BAAV Bus Builder of the Year 2010
- European Community Whole Vehicle Type Approval
- GCC Certification by the Gulf Cooperation Council
- Australian ADR Certification
- Russian GOST R Certification
- SO/TS16949: 2009 Quality System Certification
- ISO/TS14001: 2004 Environmental System Certification
- Exemption from Inspection of Export Commodities



Global Strategic Partners





In 2001, buses were exported to Middle East in batch.



In 2005, King Long passed the British Commercial Vehicle Certification (VCA Certification) and was allowed to enter the EU market; participated in BAAV European Bus Exhibition for the first time.

2000**2001****2003****2005**

In 2000, King Long buses entered Southeast Asia market.



In 2003, King Long bulk exported luxury buses to Malta, marking the first entry into the European market.





In 2008, King Long buses were exported to Hungary and Italy in batch; 300 units city buses XMQ 6121GF were exported to Angola.



In 2010, King Long sold 3000 Mini vans which provided service for World Cup in South Africa; and sold 100 large buses provided service for Singapore Youth Olympic Games.

2007 ○**2008** ○**2009** ○**2010**

In 2007, export sales exceeded 100 million USD; entered the Australian market.



In 2009, King Long export sales ranked first in Chinese bus producers, which reached more than 200 million USD; won the 'Bus Builder of the Year' in BAAV European Bus Exhibition.



In 2011, King Long joined hands with ARRIVA to export 172 units Euro V buses to Malta, marking a milestone as the first Chinese bus manufacturer to work with the EU' s largest transport operator.



In 2016, King Long exported accumulated 23,000 minivans to Egypt, sales volume of local exclusive distributor for King long minivan continuous topped in Egypt segment market.



2011 ○

2015 ○

2016 ○

2017



- In 2015, 1060 coaches exports to Saudi Arabia
- 643 luxury tourist coaches exported to Thailand.



In 2017, King Long and Baidu Released New Achievements China' s First Commercial Autonomous Driving Micro-cycle Vehicle Apolong Made Its Glorious Debut

Product





- Lengths ranging from 6-18m
- Large-sized, high-end and humanity designed

Multiple power solutions such as diesel engine, NG engine, hybrid and electric motors

Meeting the requirements of public transit routes in cities of different sizes



- Lengths ranging from 6-14m
- Fully meeting the requirements of different market segments.
- Equipment King Long Smart Cloud service platform
- In a leading position in safety, economy and comfort in the industry.



- Length Ranging from 4.8 to 5.9m
- Four major products series: Kingwin, Kingte, Kingo, Kingray
- Application of more flexible avariety of length, a variety of high degree of choice
- Providing petrol, diesel , dual fuel, hybrid engines and electric vehicles
- Widely used in passenger transport, cargo transport and business commuter

- We have developed new energy vehicles for more than a decade since 2001 , successfully developed first mix energy coach which based on lead acid battery.
- Now, We have covered 6-14m completely comprehensive product line.
- It contains mix energy vehicles, plug-in hybrid vehicles and pure electric vehicle
- Product sales nearly 10000 vehicles.



- 12 years manufacturing experience
- Professional maturity chassis and body
- Dedicated team responsible for providing solutions
- In-vehicle space and equipments can be customized



China's First Commercial Autonomous
Driving Micro-cycle Vehicle —Apolong





Manufacturing and R&D



- 1,600m production line
- Professional coach production process
- Chassis workshop
- Welding workshop
- Electrophoresis workshop
- Coating workshop
- Assembly workshop
- Daily capacity: 70 units



- Automatic assembly line
- Stamping workshop
- Coating workshop
- Welding workshop
- Assembly workshop

- Yearly capacity: 30,000 units



- 18 E-coating processes
- The electrophoretic paint becomes a layer of even, smooth and strong adhesive paint film on the surface of body frame after electrochemical reaction
- It makes the surface of body frame and inner cavity of being strongly anticorrosive, antirust, salt fog resistant and heat moist resistant
- Antirust up to 12 years, it extends the whole vehicle life span tremendously

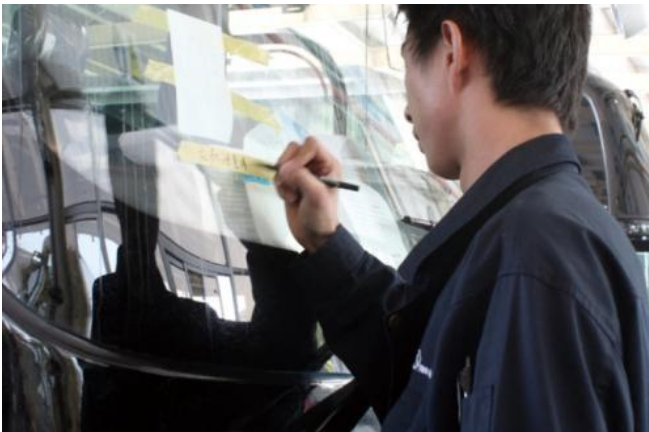

- Continues to carry out total quality management
- It took the lead to pass the certification of ISO/TS16949: 2009 Quality System
- Scientific and rigorous quality process control
- Ex factory pass rate for completed vehicles: 100%



- Dust smoke detection
- Strong ray room identification defect inspection
- Paint mirror check
- Four-wheel alignment





- By 2015, the establishment of Automotive Engineering Research Institute
- Owns 271 design patents

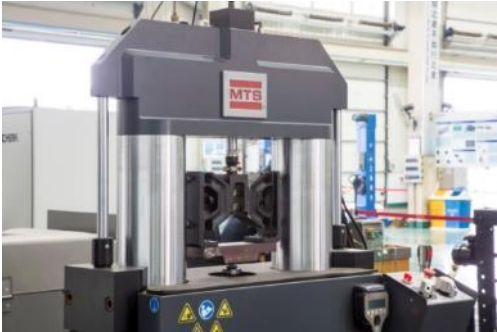

- New Energy Vehicle Test
- Complete Vehicle Road Test
- NVH & CAE Test
- Performance Test on Parts and Components
- Vibration and Durability Test of the Assembly Parts and Components by Road Simulation
- Durability Test of the Whole Vehicle by Road simulation
- Chassis Dynamometer Test
- Bench Test of Power Chain
- Power Battery Test



- 30 years R&D experience
- Over 800 R&D engineers
- Nearly 300 design patents and technological innovation



- Corporate technical centre
- Postdoctoral scientific and research workstation
- National local joint engineering laboratory
- Energy-saving and safety testing center
- International Laboratory Accreditation Cooperation
- Mutual Recognition Arrangement laboratory
- China National Accreditation Service for Conformity Assessment
- Assessment Laboratory Accreditation Certificate - China National Accreditation Service for Conformity Assessment



- More than 20 years R&D of new energy vehicles.
- Superior new energy bus technology test center in China.
- Beyond the passenger car standards for the development goals, using in line with international standards of electronic control system V R&D model.
- In 2015, independent research and development of ISG plug-in hybrid buses, marked achieving real plug-in hybrid bus.



- Smart Cloud platform is the positive result of the perfect combination of innovative technologies and coach skills.
- The platform contains three major function, operation management, safety application and energy saving application.



- Owns GPS, Driving behavior management, maintenance reminder, fuel management and battery current, voltage, temperature, insulation resistance and SOC parameters real-time monitoring function.

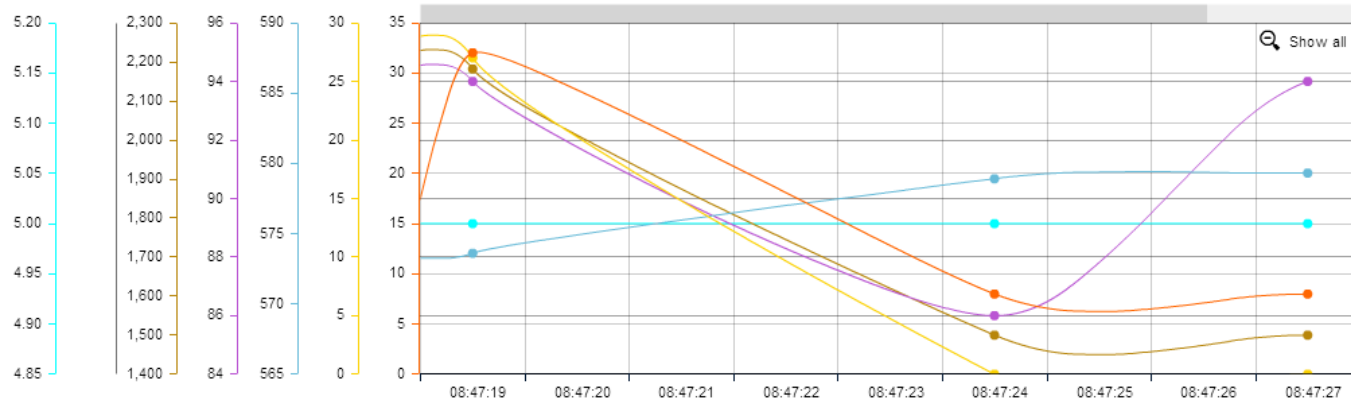

- Provide different clients in different industries the tailored system solutions.

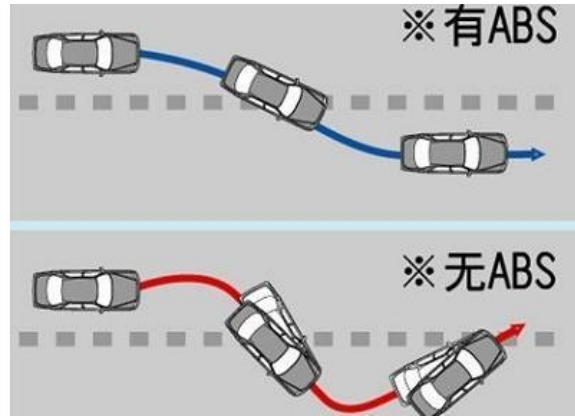
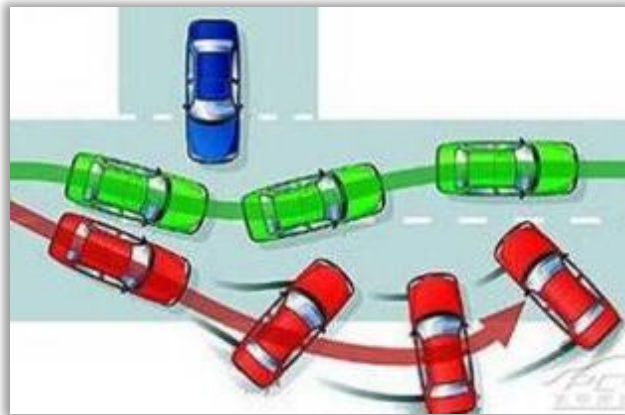
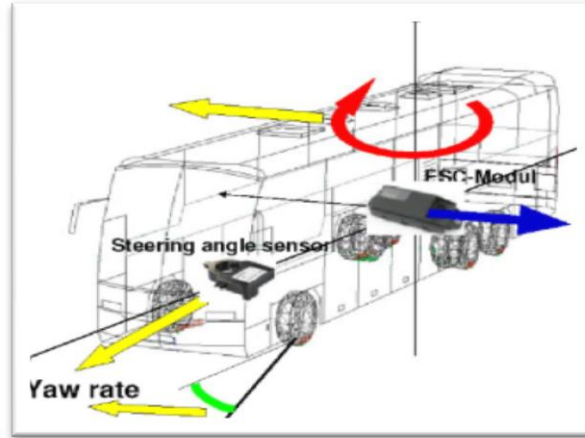

- Tire Pressure Monitoring System (TPMS)
- Vehicle Stability Control (ESC)
- Anti-roll Stabilization System (ESP)
- Anti-lock Braking System (ABS)

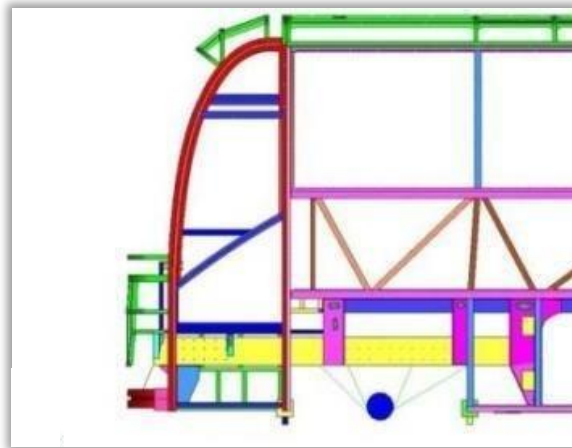
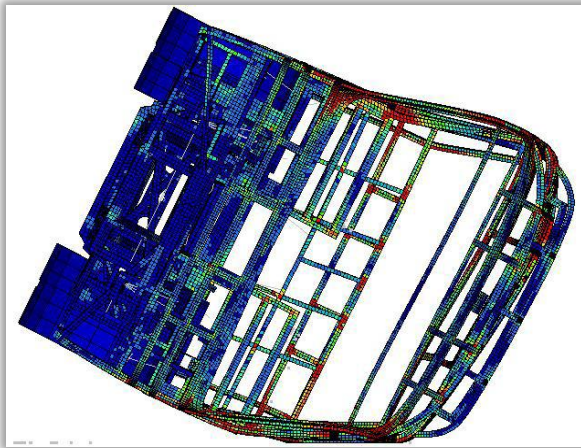
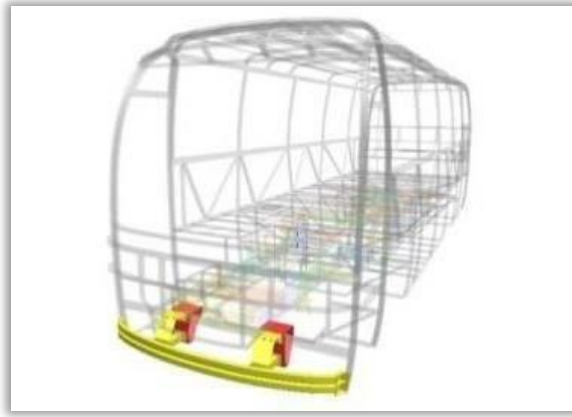
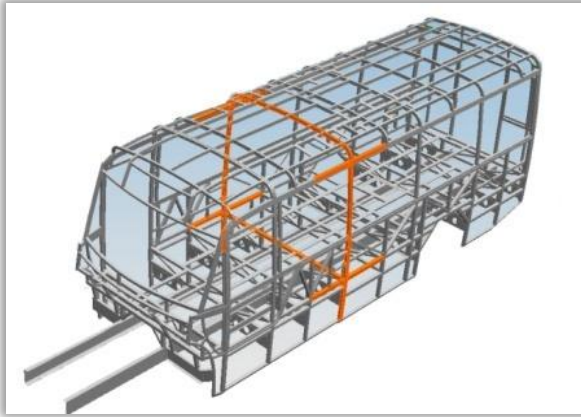

- 3H High-strength Body
- Front and Rear Buffer Beams
- Roll-over Frame Safety
- Absorbed Energy Structure



King Long Service



- 30+ offices, 100+ distributors, 300+ marketing engineers, 500+ maintenance stations around the world.
- Professional marketing engineers play roles of vehicle consultant, recommend the vehicle and configuration scheme both are the highest cost performance.
- Provides flexible and efficient vehicle buying financing plan in purchasing process.
- Regular return visit to the user, actively find problems and solve the problems during the vehicle using.



- After product sold, King Long smart cloud service platform, provides customers with intelligent vehicle operation status monitoring services.
- Safe driving management, revenues optimization management and other applications, achieved the operation of each vehicle monitoring.



- Establish more than 600 service stations in worldwide,
- 24 hours service hotline
- King Long service group provide equipment examine and repair before the season transformation and major holidays.

A group of children are captured in a joyful moment, holding hands and jumping in a park. The scene is bathed in bright, warm sunlight, creating a lens flare effect on the right side. The children are dressed in casual summer attire. A dark grey banner with white text is overlaid across the middle of the image.

Events Support Social Responsibility



- 1800 units of King Long city buses won the bidding which was 1/3 of the overall serving vehicles
- 6000 King Long buses serving in Beijing During Beijing Olympic Games



- First domestic blood collection vehicle serving in Shanghai Expo, worthy of 5 million RMB
- 76 units of XMQ6126Y3 Luxury Coach Serving in Expo special
- All the service vehicle zero failure during 184 days



- 100 King Long buses serviced Singapore Youth Olympic Games
- Professional after-sale team full guarantee
- Zero-failure operation for 13 days



- 100 units of King Long buses serviced the London Olympic Games in 2012
- Professional after-sale team full guarantee
- Zero-failure operation for 17days



- 10 units of King Long buses serviced the Ocean Ministerial Conference in 2014
- Professional after-sale team full guarantee
- Zero-failure operation
- Get highly praise from the organizing committee



- 35 units of King Long buses serviced the National Youth Games in 2015
- Professional after-sale team full guarantee
- More than 40000 passengers in total
- Zero-failure operation for 17days



- 22 units King Long EV mini-vans fully involved in the EV 100 Forum
- Protect the environment better with zero emissions
- Professional after-sale team full guarantee
- Zero-failure operation in the cold winter



King Long has supplied 233 buses to serve the airport reception for delegations of participating head of state and provide commuter service for official and commercial business during the summit.



- The “King Long Mobile Library” with 70,000 books donated to 300 schools
- Action of Earthquake Relief and Love Relay
- Sponsoring Xiamen International Marathon
- Blood donation campaign for love



Operations All over the World



UAE



Philippines



Thailand



Malaysia



Singapore



Saudi Arabia

Accumulative sales volume
from 2003 to 2017

Coach&City Bus:
15359 Units

Mini-Van:
32987 Units

**Bolivia****Cuba****Peru****Venezuela****Jamaica****Chile**

Accumulative sales volume
from 2003 to 2017

Coach&City Bus:
2836 Units

Mini-Van:
14984 Units



France



Russia



Italy



Spain



Britain



Cyprus

Accumulative sales volume
from 2003 to 2017

Coach&City Bus:
3529 Units

Mini-Van:
25 Units



Algeria



Guinea



Eritrea



Egypt



Kenya



Senegal

Accumulative sales volume
from 2003 to 2017

Coach&City Bus:
4587 Units

Mini-Van:
11318 Units



Australia



New Zealand

Accumulative sales volume
from 2003 to 2017

Coach&City Bus:
496 Units

Mini-Van:
25 Units

Thanks

